

Impact of Academic and Non-Academic Service Quality on International Students Satisfaction in Chinese Universities

Usama Kalim¹, Phuc Quang Bao Tran¹, Saira Bibi¹ & Latdavone Khamphouvong¹

¹ Faculty of Education, Southwest University, Chongqing, China

Correspondence: Usama Kalim, Faculty of Education, Southwest University, Tiansheng Road N.2, Beibei District, Chongqing, 400715, China.

Received: August 3, 2022

Accepted: September 12, 2022

Online Published: September 22, 2022

doi:10.5539/jel.v11n6p86

URL: <https://doi.org/10.5539/jel.v11n6p86>

Abstract

Satisfied students are easy to retain and perform better in academics. That consequently affects higher educational institutions' success and reputation. To become a top higher educational institution, every institution tries to provide the best academic facilities and services to its students. However, non-academic services are not given equal importance in academic settings, which could significantly determine students' satisfaction. Therefore, this paper aims to examine the impact of academic and non-academic service quality on international student satisfaction in China. This study followed a deductive approach and is carried out in a non-contrived setting. The convenience sampling technique was used in the study for data collection. A total of 143 responses from the international students is received through an online survey. Descriptive and Structured Equation Modeling (SEM) analysis techniques were performed for analyzing the variables. The results indicate that both academic and non-academic service quality equally contributes to student satisfaction. The findings of this study reveal that non-academic services aspects are as important as academic services when it comes to affecting student satisfaction. This study highlights the significance of different service quality dimensions for student satisfaction which is sometimes not given equal importance in the educational environment. The trend of the internationalization of education in China is increasing rapidly. The higher educational institutions in China need to acknowledge different aspects of students' satisfaction to become a top higher-level educational destination for international students.

Keywords: international students, student satisfaction, service quality, higher education, internationalization

1. Introduction

The global trend for education is creating a growing demand for quality higher education (Mansori et al., 2014). Accordingly, educational institutions in higher education emphasize meeting student expectations by understanding their needs and wants (Manik & Siddhartha, 2017). With the increase in the number of higher educational institutions, institutions are now competing with their local and international counterparts to provide better service quality for student satisfaction (Yousapronpaiboon, 2014). As per the authors, student satisfaction largely depends on the institutional provision of service quality. Martinez-Roget et al. (2020) stated in their study that student satisfaction in higher education is vital due to its positive influence on their performance and skills acquisition level. Quality service in higher education is essential for providing better learning experiences to the students and their overall satisfaction (Pathmini et al., 2014). Higher educational institutions are bringing better service quality to attract students and improve their performance (Eshun et al., 2018).

Service quality is the key to student satisfaction in higher education institutions (Hwang & Choi, 2019), emphasizing the student as the primary stakeholder (Hassan et al., 2020). Effective higher education institutions provide better service quality for attracting and retaining students (Li & The, 2021). Further concentration on student needs and expectations is of maximal significance for higher educational institutions to keep a good image for the students (Uddin et al., 2018).

In the past, students from China used to travel to other countries to pursue higher education (Jiani, 2017). China has recently become a top attraction for international students (Frezghi & Tsegay, 2019). These students are becoming part of higher education institutions to present a mixed view of internationalization in higher education in China (Han et al., 2020). To support this growing trend of internationalization, China has been making efforts to sustain and promote this trend (Li & The, 2021).

This study aims to investigate the satisfaction level of international students studying in Chinese higher education and to provide evidence of the academic and non-academic service quality on student satisfaction. For that purpose, the international students studying at Southwest University (SWU) and Chongqing Normal University, China, are taken as a sample for this study. The objectives of this study are as follows:

- To determine the relationship between academic service quality and international student satisfaction.
- To determine the relationship between non-academic service quality and international student satisfaction.
- To determine which variable (academic or non-academic) has a more significant impact on student satisfaction.

2. Review of Literature

2.1 Internationalization of Higher Education in China

In the last two decades worldwide, the internationalization of higher education has become a prominent agenda (Yang, 2016). According to the author, the internationalization trend is increasing rapidly worldwide due to the modern age of globalization. With the rise of economic power and advancement in several other fields, the transformation of higher education has become a key objective of China (Ma & Yue, 2015). To transform higher education and bring quality to it, the internationalization of Chinese higher education has become a key area of focus (Biney & Cheng, 2021). The authors also stated that the government is taking measures to promote internationalization with financial and diplomatic leverages. Over the years, large-scale funding has been provided to higher education institutes to attract new international students (Li, 2016). The focus has also shifted to promoting Chinese-international student interaction to provide exposure to the local Chinese students (Frezghi & Tsegay, 2019).

2.2 Service Quality Impact on Student Satisfaction

A student in an institution defines service quality making it difficult for institutions to understand which aspect of the services students consider quality education service (Sharif & Kassim, 2012; Encinas & Ammigan, 2016). Since students' educational experience is subjective and intangible, measuring its quality poses a challenge for higher education administrators (Arrivabene et al., 2019). Hence, numerous education sectors have invested a great deal of effort in analyzing and understanding the factors leading to higher education student satisfaction.

Parasuraman et al. (1985) classified service quality into two subparts: expected and perceived service. Accordingly, perceived service quality is the outcome of evaluating demands and perceptions (Parasuraman et al., 1988). Meanwhile, the expectations are based on service criteria and students' perceptions of service quality (Gronroos, 2007). The quality of services obtained, consisting of dimensions such as reliability, assurance, measurability, recognition of other people's souls, and reaction ability, is compared with expectations (Cahyono et al., 2020).

Parasuraman and colleagues (1988) have also developed several measurement instruments, i.e., the Service Quality Scale (SERVQUAL Scale), to analyze service quality. SERVQUAL Scale has been widely selected as the model for measurement due to its comprehensive approach (Hassan et al., 2019). This SERVQUAL model has been commonly applied in social sciences to evaluate service quality (Hassan et al., 2020).

Remarkably, in educational institutions, the SERVQUAL model has been regularly used to measure the service quality perceived by the students (Chandra et al., 2019; Kanakana, 2014; Mansori et al., 2014; Yousapronpaiboon, 2014). According to the study by Hwang and Choi (2019), higher education institutions shape students' perception of university image by its service quality. Additionally, the study supported by Hassan et al. (2019) also indicated that the measurement model influenced student satisfaction mainly by service quality provided at the university.

In the Asian context, Annamdevula and Bellamkonda (2016) conducted a study in the Indian higher educational context. The study's results also revealed a significant positive relationship between these variables. The survey conducted by Duarte et al. (2012) disclosed that increased service quality leads to increased student satisfaction. Similarly, research on Malaysian higher education concluded a similar relationship between these variables (Mansori et al., 2014). As stated by many studies discussed earlier, it is clear that service quality does affect student satisfaction.

2.3 Student Satisfaction

As per Alves and Raposo (2010), student satisfaction represents the value comparison between the expected service qualities from the institution vs the perceived experience gained. At the same time, some researchers conceptualized this as "a student's overall attitude in the educational setting which is the result of educational

experience” (Elliott & Healy, 2001, p. 2). With the trend of internationalization in higher education, this concept of student satisfaction has become more critical for higher educational institutions (Wang & Tseng, 2011).

2.4 Why Student Satisfaction Is Essential for Their Performance

Student satisfaction has been associated strongly with student performance (Dalton & Denson, 2009). It has a direct positive relationship with student performance, meaning that more satisfied students will perform better than their counterparts (Rad & Yarmohammadian, 2006). In support of this view, Risch-Rodie and Kleine (2000) stated in their study that the students would be more attentive, loyal, and decent performers if they were satisfied within the educational setting. Because students’ level of satisfaction upsurges and enable students’ logical cognitive and aptitude growth (Dalton & Denson 2009).

Siming et al. (2015) stated in their study that student satisfaction affects student performance to a great extent. According to the authors, a feeling of satisfaction means that the students enjoy their time in the university, which eventually determines how well a student performs. Similarly, Barnett (2011) stated that student satisfaction is important as this directly impacts their academic performance. In another study, according to Khosravi et al. (2013), focusing on the students’ satisfaction is most important for the university’s reputation. A higher level of student satisfaction helps higher education institutions lower dropouts, directly impacting scores (Alves & Raposo, 2009).

These studies highlight the importance of student satisfaction for higher educational institutions. As the global competition in higher education is rising, more emphasis has been given to the factors which can improve institution performance and enable this institution to be globally competitive. From the literature discussion above, this study presents the following conceptual framework to understand and explain this phenomenon and variables.

2.5 Theoretical Framework

A research framework has been established based on the extant review of the literature to explore the influence of academic and non-academic service quality impact on international student satisfaction. Student satisfaction is the dependent variable, and academic and non-academic service quality are independent variables. The research framework is illustrated in Figure 1 below:

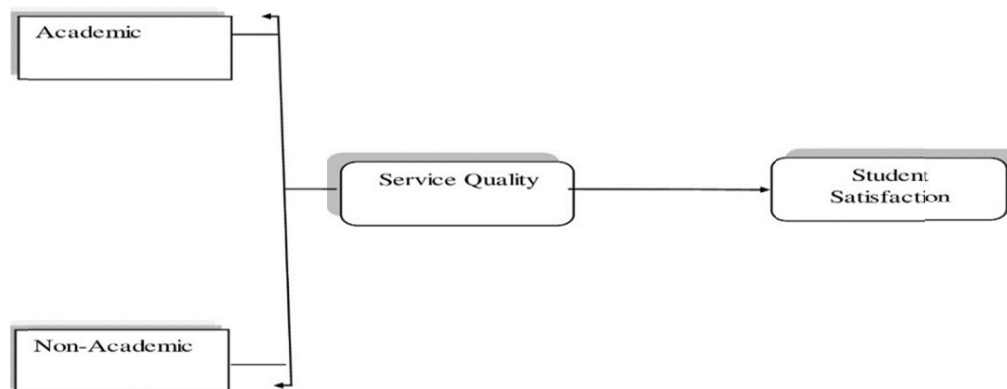

Figure 1. Conceptual framework based on literature review

3. Research Methodology

3.1 Research Design

This study followed a deductive approach, which is descriptive as it describes certain characteristics and relationships of variables. This study was conducted in a non-contrived setting as the data was collected in the virtual university environment. Additionally, the research design of this study was cross-sectional as the data were collected from different students at the same point in time.

3.2 Population and Sampling

The population of the study covers all undergraduate and graduate international students studying at Southwest University, Chongqing, China. The convenience sampling technique was used in the study for data collection. A total of 143 responses were received through an online survey. Out of this number, 85 complete responses were selected for further analysis.

3.3 Instrument

The scale developed by (Uddin et al., 2018; Fares et al., 2013) was used in this study to measure the variables, which were then further adapted to suit the particular context. A structured questionnaire with the format of 5-point Likert scaling was applied for collecting primary data. The questionnaire has four parts. The details of which are given in the Table 1:

Table 1. Summary of construct

Variable	Dimension	Indicators
Service Quality	1) Academic Services	Eight items
	2) Non-Academic Services	Seven items
Student Satisfaction	Overall	Seven items

The first part consists of demographic-related information such as gender, age group, degree, and time spent in the university. The second part is related to independent variables, i.e., academic, non-academic services, university facilities, and university reputation. In the third part, students' overall satisfaction is measured by seven questions.

3.4 Analysis Techniques

Cronbach's alpha methodology has been used in this study to test the reliability of the constructed variable. According to Sekaran and Bougie (2011), Cronbach's alpha measures the reliability coefficient, which indicates the homogeneity of group items of a particular scale. As per the standards set in the social sciences for Cronbach's alpha acceptable value, Cronbach's α less than 0.60 is considered poor, those in the 0.70 range acceptable, and those over 0.80 thought good. Therefore, the internal consistency reliability is checked through these alpha coefficients. The collected data were then processed with the assistance of SPSS and AMOS software.

4. Data Analysis

4.1 Demographic Analysis

For testing the hypothesis of this study, a quantitative approach was adopted in this study. The primary data was collected by using an online instrument. A total of 143 responses were received through an online survey. Out of this number, 85 complete responses were valid for further analysis. The details about the demographic factors of participants are presented in Table 2. As per the results shown in Table 2, most of the respondents are female (61.2%). Most of the participants age lies in the age group of 25–30, indicating younger participants for the study. The majority of respondents are enrolled in bachelor's and master's degrees, having one year to 2 years of experience in the university (see Table 2).

Table 2. Demography analysis

		Frequency	Per cent			Frequency	Per cent
Gender	Male	33	38.8	Degree	Bachelor	31	36.5
	Female	52	61.2		Masters	18	21.2
	Total	85	100		PhD	22	25.9
Age Group	26–30	52	61.2	Time Spent	Other	14	16.5
	31–35	25	29.4		One year	53	62.3
	36–40	8	9.4		Two years	22	25.9
	Total	85	100		2 Years +	10	11.7

4.2 Descriptive Statistics

Table 3 demonstrates descriptive statistics for the studied variables. As per the table results, all the mean scores are above three on the five-point Likert scale, showing the respondents' positive responses. The student satisfaction variable means value is close to 4 (3.8487), showing the satisfaction level of international students at the university.

The other variable mean value is also more than three, indicating that students positively rate those services provided at university. This study confirms the normality of data by endorsing the values of skewness and kurtosis in the analysis. The Skewness and kurtosis values given in Table 3 lie in the normal range. The value

range of -1 to $+1$ for skewness is considered standard for normal distribution, while the kurtosis value should be in the range of -2 to $+2$ to ensure normal distribution (Geotge & Mallery, 2010).

Table 3. Descriptive statistics

Constructs	No. of Items	Mean	Std. Deviation	Skewness	Kurtosis
Academic	8	3.6044	.53759	-.820	-.073
Non-Academic	7	3.6403	.56956	-.618	.194
Student Satisfaction	7	3.8487	.61261	-.744	1.013

4.3 Reliability Measures

It is necessary to measure the reliability of the construct before modelling their relationship (Zainudin, 2012). To ensure uni-dimensionality in the SEM analysis, the factor loadings should be 0.60 or higher for scales (Zainudin, 2012). In accordance, the researcher only included those items which a score value above 0.60. Doing so allows the researcher to have uni-dimensionality in construct items. The Average Variance Extracted (AVE) test has been used for assessing convergent validity. According to this test, the reliable variables can have less than 50 per cent explained variance (Fornell & Larcker, 1981). The convergent validity column (AVE section) shows that the value of variables stretched from 0.43 to 0.49, attaining convergent validity. Composite reliability has been selected to verify the convergent validity further. The generally accepted value of composite reliability in social sciences is 0.70 or above (Hair et al., 2009). The extracted value in this study is stretched from 0.8 to 0.86, ensuring the composite reliability of the construct. In the context of the social sciences, Cronbach's Alpha test requires the item value to be greater than 0.7 to be a reliable model (Hair et al., 2013). Moreover, Cronbach's alpha value is more than 0.8 for all the variables, confirming the internal reliability of the instrument. This evidence is proved and demonstrated in Table 4.

Table 4. Reliability, validity, and uni-dimensionality assessment

Constructs	Factor Loading	Cronbach Alpha	Composite Reliability	Average Variance Extracted (AVE)
Academic Quality		0.87	0.86	0.48
A8	0.839			
A7	0.706			
A6	0.678			
A5	0.962			
A4	0.885			
A3	0.624			
A2	0.603			
A1	0.667			
Non-Academic Quality		0.83	0.80	0.43
NA7	.712			
NA6	.939			
NA5	.766			
NA4	.759			
NA3	.696			
NA2	.677			
NA1	.796			
Student Satisfaction		0.82	0.81	0.49
SS1	.7118			
SS2	.941			
SS3	.775			
SS4	.851			
SS5	.634			
SS6	.679			
SS7	.871			

4.4 Discriminant Validity

The correlation test has been performed to ensure the discriminant validity of the instrument. According to Kline (2011), achieving discriminant validity requires correlation values between two constructs to be below 0.85. However, some scholars also recommended a higher value of 0.90 as the threshold point for ensuring discriminant validity (Gold et al., 2001; Teo et al., 2008). These researchers suggested that a value below the threshold point of 0.90 enable you to escape multi-collinearity. This study has a correlation value of 0.674, attaining the standard to escape multi-collinearity between the variables (See Table 5).

Table 5. Correlation of variables

Correlations		NonAcademic	Academic
NonAcademic	Pearson Correlation	1	.674**
	Sig. (2-tailed)		.000
	N	85	85
Academic	Pearson Correlation	.674**	1
	Sig. (2-tailed)	.000	
	N	85	85

** . Correlation is significant at the 0.01 level (2-tailed).

4.5 Structural Equation Modeling

The relationship between the variables identified using the AMOS path diagram is presented in Figure 2. The results show that student satisfaction (SS) has a positive relationship with both the exogenous variables, as shown in the figure below:

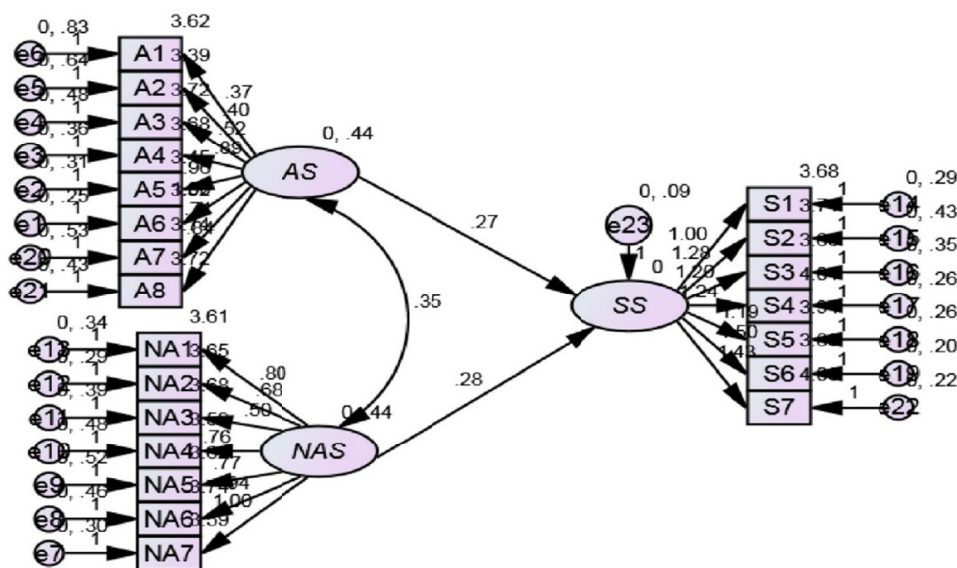

Figure 2. SEM analysis of variables

The explanation of their relationship is given in Table 6. The regression results in Table 6 indicate that both academic and non-academic services have a significant positive relationship with student satisfaction. The value of (.271, $p = .048$) for academic services and (.281, $p = .043$) for non-academics shows a significant positive relationship with student satisfaction. The previous studies conducted in this area also found a significant positive relationship between these variables in different contexts (Eshun et al., 2018; Hassan et al., 2019). The key point of this research is to explore the relationship between latent variables and student satisfaction and to understand how academic and non-academic service quality matters for student satisfaction. The analysis reveals that both Academic Services (AS) and Non-academic Services (NAS) contribute equally to student satisfaction.

Table 6. Regression weights: (Group number 1—Default model)

			Estimate	S.E.	C.R.	P
Satisfaction	<---	AcademicServices	.271	.137	1.975	.048
Satisfaction	<---	NonAcademicServices	.281	.139	2.019	.043

5. Discussion & Conclusion

5.1 Discussion

The key point of this research is to explore the relationship between latent variables and student satisfaction and to understand how academic and non-academic service quality matters for student satisfaction. This study discloses reasonable results to conclude that student satisfaction is affected by both academic and non-academic services. Previous studies on this area also found a significant positive relationship between these variables in different contexts (Eshun et al., 2018; Hassan et al., 2019). However, most of the studies focused on the effects of academic service on student satisfaction (Manik & Sidharta, 2017; Hassan et al., 2019; Hwang & Choi, 2019). This study highlighted that non-academic services are also crucial and equally important for the student's satisfaction in the academic environment (Pitaloka & Hapsoro, 2020).

5.2 Conclusion

From the discussion above, this study concluded that academic or non-academic service quality contributes to student satisfaction. Hence, this highlights the need for higher educational institutions to give equal importance to both services. Higher educational institutes in China need to emphasize service quality as it affects student satisfaction and leads to improved student performance, loyalty behaviour, and intention to leave (Bakrie et al., 2019; Dib & Alnazer, 2013). Wang and Tseng (2011) stated in a study that satisfaction with the institution was the leading cause behind student motivation to choose and stay at a Chinese university. Therefore, to become an educational economy and attract more international students to higher education, China needs to focus on this quality aspect of services (Biney & Cheng, 2021).

However, the results of this study cannot be taken as independent of other factors present in the regular university environment, which also plays a role in student satisfaction. But as the global competitiveness in higher education is growing worldwide, one can understand the importance of these variables for student satisfaction (Eshun et al., 2018).

6. Recommendations

This study highlights the importance of both academic and non-academic service quality for students' satisfaction, which is the key factor for the success of any higher educational institution. This study was done from students' point of view, and to improve the efficiency and effectiveness of services offered, international students' opinions must be considered (Maria, 2020). This study also implies that Chinese universities must emphasize equally on academic and non-academic service quality aspects to provide better student experiences.

References

- Alves, H., & Raposo, M. (2009). The measurement of the construct satisfaction in higher education. *The Service Industries Journal*, 29(2), 203–218. <https://doi.org/10.1080/02642060802294995>
- Alves, H., & Raposo, M. (2010). The influence of university image on student behavior. *International Journal of Educational Management*, 24(1), 73–85. <https://doi.org/10.1108/09513541011013060>
- Annamdevula, S., & Bellamkonda, R. S. (2016). Effect of student perceived service quality on student satisfaction, loyalty and motivation in Indian university. *Journal of Service Management*, 11(2), 488–517. <http://doi.org/10.1108/MBE-09-2016-0047>
- Arrivabene, L. S., Vieira, P. R. C., & Mattoso, C. L. Q. (2019). Impact of service quality, satisfaction and corporate image on loyalty: A study of a publicly-traded for-profit university. *Services Marketing Quarterly*, 40(3), 189–205. <https://doi.org/10.1080/15332969.2019.1630174>
- Bakrie, M., Sujanto, B., & Rugaiyah, R. (2019). The influence of service quality, institutional reputation, students' satisfaction on students' loyalty in higher education institution. *International Journal for Educational and Vocational Studies*, 1(5), 379–391. <https://doi.org/10.29103/ijevs.v1i5.1615>
- Barnett, R. (2011). The marketized university: Defending the indefensible, in Molesworth. In *The Marketisation of Higher Education and the Student as Consumer* (pp. 39–52). Routledge.

- Biney, P. A., & Cheng, M. Y. (2021). International Students' Decision to Study in China: A Study of Some Selected International Students from Universities in China. *Open Journal of Social Sciences*, 9(8), 305–325. <https://doi.org/10.4236/jss.2021.98021>
- Cahyono, Y., Purwanto, A. S., Azizah, F. N., Fitriaty, W. H., Sihotang, M., & Sugianto, A. (2020). Impact of service quality, university image and students' satisfaction towards student loyalty: evidence from Indonesian private universities. *Journal of Critical Review*, 7(19), 3916–3924. <https://ssrn.com/abstract=3873702>
- Chandra, T., Martha, N., Chandra, S., & Priyono, P. (2019). The effect of service quality on student satisfaction and student loyalty: An empirical study. *Journal of Social Studies Education Research*, 9(3), 109–131. <https://jsser.org/index.php/jsser/article/view/282>
- Dalton, H., & Denson, N. (2009). *Student evaluation: what predicts satisfaction? The Student Experience* (pp. 100–110). Proceedings of the 32nd HERDSA Annual Conference, Darwin. Retrieved from <https://www.herdsa.org.au/publications/conference-proceedings/research-and-development-higher-education-student-experience-15>
- Di Maria, D. (2020). A Basic Formula for Effective International Student Services. *Journal of International Students*, 10(3), 25–38. <https://doi.org/10.32674/jis.v10i3.2000>
- Dib, H., & Alnazer, M. (2013). The impact of service quality on student satisfaction and behavioral consequences in higher education services. *International Journal of Economy, Management and Social Sciences*, 2(6), 285–290.
- Duarte, P. O., Raposo, M. B., & Alves, H. B. (2012). Using a satisfaction index to compare students' satisfaction during and after higher education service consumption. *Tertiary Education and Management*, 18(1), 17–40. <https://doi.org/10.1080/13583883.2011.609564>
- Elliott, K. M., & Healy, M. A. (2001). Key factors influencing student satisfaction related to recruitment and retention. *Journal of Marketing for Higher Education*, 10(4), 1–11. https://doi.org/10.1300/J050v10n04_01
- Eshun, E. F., Badu, A. K., & Korwu, P. (2018). Impact of service quality on students' satisfaction in a Ghanaian public tertiary institution. *International Journal of Learning and Development*, 8(3), 97–112. <https://doi.org/10.5296/ijld.v8i3.13447>
- Fares, D., Achour, M., & Kachkar, O. (2013). The impact of service quality, student satisfaction, and university reputation on student loyalty: A case study of international students in IIUM, Malaysia. *Information Management and Business Review*, 5(12), 584–590. <https://doi.org/10.22610/imbr.v5i12.1091>
- Fornell, C., & Larcker, D. F. (1981). Evaluating structural equation models with unobservable variables and measurement error. *Journal of Marketing Research*, 18(1), 39–50. <https://doi.org/10.1177/002224378101800104>
- Frezghi, T. G., & Tsegay, S. M. (2019). Internationalization of Higher Education in China: A Critical Analysis. *Social Change*, 49(4), 643–658. <https://doi.org/10.1177/0049085719886693>
- George & Mallery. (2010). *SPSS for windows a step by step: A Simple Guide and Reference*.
- Gold, A. H., Malhotra, A., & Segars, A. H. (2001). Knowledge management: an organizational capabilities perspective. *Journal of Management Information Systems*, 18(1), 185–214. <https://doi.org/10.1080/07421222.2001.11045669>
- Hair, J. F. (2009). *Multivariate data analysis*.
- Hair, J. F., Ringle, C. M., & Sarstedt, M. (2013). Partial least squares structural equation modeling: Rigorous applications, better results and higher acceptance. *Long Range Planning*, 46(2), 1–12. <https://doi.org/10.1016/j.lrp.2013.01.001>
- Han, Y., Li, W., Bao, M., & Cao, X. (2020). An investigation of the experiences of working with multilingual international students among local students and faculty members in Chinese universities. *Sustainability*, 12(16), 6419. <https://doi.org/10.3390/su12166419>
- Hassan, S., Buang, R. R., Wahab, M. I., Shamsudin, M. F., & Hasim, M. A., (2020). Exploring mediating role of corporate image between service quality and student loyalty using PLS-SEM. *International Journal of Innovative Technology and Exploring Engineering*, 9(3), 2726–2730. <https://doi.org/10.35940/ijitee.C9233.019320>

- Hassan, S., Shamsudin, M. F., Hasim, M. A., Mustapha, I., Jaafar, J., Aadruthdin, K. F., ... Ahmad, R. (2019). Mediating effect of corporate image and students' satisfaction on the relationship between service quality and students' loyalty in TVET HLIs. *Asian Academy of Management Journal*, 24(1), 93–105. <https://doi.org/10.21315/aamj2019.24.s1.7>
- Hwang, Y., & Choi, Y. (2019). Higher education service quality and student satisfaction, institutional image, and behavioral intention. *Social Behavior and Personality: An International Journal*, 47(2), 76. <https://doi.org/10.2224/sbp.7622>
- Jiani, M. A. (2017). Why and how international students choose Mainland China as a higher education study abroad destination. *Higher Education*, 74(4), 563–579. <https://doi.org/10.1007/s10734-016-0066-0>
- Kanakana, M. G. (2014). *Assessing service quality in higher education using the SERVQUAL tool* (vol. 1, pp. 68–74). International Conference on Industrial Engineering and Operations Management. Retrieved from <http://ieomsociety.org/ieom2014/pdfs/24.pdf>
- Khosravi, A., Poushaneh, K., Roozegar, A., & Sohrabifard, N. (2013). Determination of factors affecting student satisfaction at Islamic Azad University. *Procedia – Social and Behavioral Sciences*, 84(4), 579–583. <https://doi.org/10.1016/j.sbspro.2013.06.607>
- Kline, R. B. (2011). *Principles and practice of structural equation modeling* (3rd ed.). The Guilford Press. New York.
- Li, F. (2016). The internationalization of higher education in China: The role of government. *Journal of International Education Research*, 12(1), 47–52. <https://doi.org/10.19030/jier.v12i1.9566>
- Ma, W., & Yue, Y. (2015). Internationalization for quality in Chinese research universities: student perspectives. *Higher Education*, 70(2), 217–234. <https://doi.org/10.1007/s10734-015-9899-1>
- Manik, E., & Siddharta, I. (2017). *The impact of academic service quality on student satisfaction* (pp. 1–6). International Conference on Accounting, Management, Economics and Social Sciences (May 2017). MPRA Paper. Retrieved from <https://mpra.ub.uni-muenchen.de/80878/>
- Mansori, S., Vaz, A. F., & Ismail, Z. (2014). Service quality, satisfaction and student loyalty in Malaysian private education. *Asian Social Science*, 10(7), 57–66. <https://doi.org/10.5539/ass.v10n7p57>
- Martínez-Roget, F., Freire Esparís, P., & Vázquez-Rozas, E. (2020). University student satisfaction and skill Acquisition: Evidence from the undergraduate dissertation. *Education Sciences*, 10(2), 1–15. <https://doi.org/10.3390/educsci10020029>
- Parasuraman, A., Zeithaml, V. A., & Berry, L. L. (1985). A conceptual model of service quality and its implications for future research. *The Journal of Marketing*, 49(4), 41–50. <https://doi.org/10.1177/002224298504900403>
- Parasuraman, A., Zeithaml, V. A., & Berry, L. L. (1988). SERQUAL: A multiple-item scale for measuring consumer perceptions of service quality. *Journal of Retailing*, 64(1), 2–40. Retrieved from https://www.researchgate.net/publication/225083802_SERVQUAL_A_multiple-Item_Scale_for_measuring_consumer_perceptions_of_service_quality
- Pathmini, M. G. S., Wijewardana, W. P., Gamage, C. T., & Gamini, L. P. S. (2014). Impact of service quality on student's satisfaction in newly established public sector universities in Sri Lanka: Study based on the faculty of management studies. *Journal of Management Matters*, 1(1), 51–64. <http://repository.rjt.ac.lk:8080/xmlui/handle/123456789/893>
- Perez-Encinas, A., & Ammigan, R. (2016). Support Services at Spanish and U.S. Institutions: A Driver for International Student Satisfaction. *Journal of International Students*, 6(4), 984–998. <https://doi.org/10.32674/jis.v6i4.330>
- Pitaloka, L. K., & Hapsoro, B. B. (2020). Analyzing Universities Service Quality to Student Satisfaction; Academic and Non-Academic Analyses. *International Journal of Higher Education*, 9(1), 126–132. <https://doi.org/10.5430/ijhe.v9n1p126>
- Rad, A. M. M., & Yarmohammadian, M. H. (2006). A study of relationship between managers and employees' job satisfaction. *Leadership in Health Services*, 19(2), 11–28. <https://doi.org/10.1108/13660750610665008>
- Risch-Rodie, A., & Kleine, S. S. (2000). Customer participation in services production and delivery. In T. A. Swartz & D. Iacobucci (Eds.), *Handbook of Services Marketing and Management* (pp. 111–125). Beverly Hills, California: Sage Publications. <https://doi.org/10.4135/9781452231327.n10>

- Sharif, K., & Kassim, N. M. (2012). Non-academic service quality: Comparative analysis of students and faculty as users. *Journal of Marketing for Higher Education*, 22(2), 35–54. <https://doi.org/10.1080/08841241.2012.705793>
- Siming, L. (2015). Factors leading to student's satisfaction in the higher learning institutions. *Journal of Education and Practice*, 6(31), 114–118. <https://files.eric.ed.gov/fulltext/EJ1083362.pdf>
- Teo, T. S. H., Srivastava, S. C., & Jiang, L. (2008). Trust and electronic government success: an empirical study. *Journal of Management Information Systems*, 25(3), 99–132. <https://doi.org/10.2753/MIS0742-1222250303>
- Uddin, M., Ali, K., & Khan, M. A. (2018). Impact of service quality (SQ) on student satisfaction: empirical evidence in the higher education context of emerging economy. *Journal of Islamic Social Sciences and Humanities*, 16(2), 31–67. <https://doi.org/10.33102/abqari.vol16no1.8>
- Wang, R., & Tseng, M. L. (2011). Evaluation of international student satisfaction using fuzzy importance-performance analysis. *Procedia – Social and Behavioral Sciences*, 25(4), 438–446. <https://doi.org/10.1016/j.sbspro.2012.02.055>
- Yang, R. (2016). Internationalization of higher education in China. In S. Guo & Y. Guo (Eds.), *Spotlight on China*. Rotterdam: Sense Publishers. https://doi.org/10.1007/978-94-6300-669-9_3
- Yousapronpaiboon, K. (2014). SERVQUAL: Measuring higher education service quality in Thailand. *Procedia – Social and Behavioral Sciences*, 116(3), 1088–1095. <https://doi.org/10.1016/j.sbspro.2014.01.350>
- Zainudin, A. (2012). *Structural equation modeling using AMOS graphics*. PENERBIT PRESS, University Technology Mara.

Copyrights

Copyright for this article is retained by the author, with first publication rights granted to the journal.

This is an open-access article distributed under the terms and conditions of the Creative Commons Attribution license (<http://creativecommons.org/licenses/by/4.0/>).