

The Development of a Digital Literacy Assessment Tool for Thai Grade 10-12 Students

Nattapon Yotha¹

¹ Department of Educational Measurement, Evaluation and Research, Faculty of Education, Phetchabun Rajabhat University, Phetchabun, Thailand

Correspondence: Nattapon Yotha, Faculty of Education, Phetchabun Rajabhat University, Phetchabun, Thailand.
E-mail: Nattapon.yot@pcru.ac.th

Received: December 8, 2024

Accepted: January 24, 2025

Online Published: February 1, 2025

doi:10.5539/hes.v15n1p276

URL: <https://doi.org/10.5539/hes.v15n1p276>

Abstract

The current study aimed to create and validate a digital literacy assessment tool's quality for students in Grades 10-12 within the Thai educational context, and 2) to develop T-score norms derived from the results of the digital literacy assessment tool for students in Grades 10-12 in this context. The study followed a research and development (R&D) approach, including content validation, pilot testing, and confirmatory factor analysis (CFA) for construct validation. The participants consisted of 1,590 Grade 10-12 students from schools under the Phetchabun Secondary Educational Service Area Office, Thailand. Content validity was assessed using the Index of Congruence (IOC), and construct validity was verified using confirmatory factor analysis (CFA). Item difficulty, discrimination indices, and reliability (KR-20) were also analyzed. The results showed that the assessment tool demonstrated strong content validity (IOC = 0.60-1.00), acceptable difficulty levels (0.20-0.80), and discrimination indices (0.22-0.74). CFA confirmed the six-component model with excellent fit indices. The tool's overall reliability was 0.94, with component reliability ranging from 0.70 to 0.83. T-score norms were developed to interpret student performance. This study provides a systematically validated digital literacy assessment tool tailored to the Thai educational context, supporting effective measurement and development of students' digital competencies.

Keywords: digital literacy, assessment tool, CFA

1. Introduction

In last ten years, digital technology has played a significant role in transforming human lifestyles as it has played a significant role in communication, work, and learning and is recognized as a fundamental skill in many countries for living in a rapidly changing society (Hennessy et al., 2022; Yeşilyurt & Vezne, 2023; Yuangsoi & Wannakhao, 2023). However, digital literacy is not limited to the efficient use of information and communication technology (ICT), it encompasses understanding the context of technology use, critical thinking, creating and managing digital content, effective communication through digital media, and ethical and responsible behavior in the online world (Buckingham, 2015; Eshet, 2012). Therefore, it is also essential for stakeholders in education to raise awareness of digital literacy for students in the current education era.

For high school students who are in a susceptible age of digital engagement and are influenced by online interactions, digital platforms, and rapidly evolving technological trends, digital literacy is critical in an era where information flows rapidly (Arık & Kıyıcı, 2019; Laudato & Punzalan, 2021). According to Castek et al. (2018), the terms digital literacy could be referred to as the ability to utilize technology effectively to locate, assess, organize, produce, and share information, while also fostering digital citizenship and encouraging the ethical use of technology. For the context of the current study, high school students in Grades 10-12 face increasing challenges in selecting and using digital information effectively, especially in an age where misinformation and fake news can spread easily and quickly. Therefore, it is important to help them gain the qualification as student in this his age group is preparing for higher education or entering the workforce, both of which require the skills to adapt and succeed in a digital society (Livingstone et al., 2017).

Digital literacy has been examined and advanced in different theories and research. Eshet's (2012) model is a well-known framework that proposes digital literacy encompasses various aspects such as information access, critical thinking, content creation, communication, and personal data management in the digital realm. These

ideas are the foundation for creating thorough assessment instruments to gauge students' digital literacy skills. Likewise, Buckingham (2015) stresses the need to enhance abilities in recognizing reliable information, grasping digital culture, and acting ethically in the online world. His perspective underscores the significance of grasping the context of digital information and media literacy within the realm of digital literacy. Media literacy assists students in distinguishing between truthful and deceptive information and critically examining and assessing data. Moreover, digital literacy is connected to ethical issues when utilizing digital media, including respecting others' rights, avoiding copyright violation, and acting responsibly on the internet. Acquiring these skills is crucial in readying students to navigate the digital society safely and responsibly (Livingstone et al., 2017).

In the Thai context, developing digital literacy skills among Grade 10-12 students is one a significant challenges in the education system (Janthapassa et al., 2024). Despite integrating ICT into the education, digital literacy levels among students vary widely due to factors such as access to technological resources, internet availability, and teachers' knowledge and understanding (Janthapassa et al., 2024; Sayavaranont & Wannapiroon, 2017; Yuangsoi & Wannakhao, 2023). The lack of accurate and comprehensive assessment tools to evaluate students' digital literacy skills is a critical issue. Without proper assessment, educators and administrators cannot develop teaching strategies that meet students' needs effectively (Ministry of Education, 2018).

Currently, research on digital literacy remains limited, particularly in the Thai educational context. Scholars (e.g., Amin et al., 2021; Avinç & Doğan, 2024; Choi et al., 2023; Hermansen et al., 2023; Yeşilyurt & Vezne, 2023) have presented assessment tool developed by research-based methodology. For example, Amin, Malik, and Akkaya (2021) developed the Digital Literacy Scale (DLS) focusing on higher education students, emphasizing basic skills such as internet use, software management, and digital communication. Similarly, Avinç and Doğan (2024) created an assessment tool utilizing the Rasch model to ensure reliability in evaluating digital competencies across various target groups. These studies highlight the need for precise and reliable assessment tools, consistent with contemporary research methodologies, particularly in content validity and confirmatory factor analysis (CFA). Conversely, Choi et al. (2023) designed a digital literacy questionnaire tailored to the daily lives of older adults, focusing on digital capabilities relevant to daily activities. Although their target audience differs from high school students, the emphasis on context-specific adaptation aligns with the development of assessment tools for Thai students in Grades 10-12. Furthermore, Hermansen et al. (2023) conducted CFA to assess the reliability of the eHealth Literacy Questionnaire (eHLQ) within healthcare systems, paralleling the use of CFA in this study to evaluate structural validity and its application to specific target groups.

However, it seems that the issues have not been mentioned in the Thai context. In detail, existing studies in the context (Sayavaranont & Wannapiroon, 2017; Yuangsoi & Wannakhao, 2023) often fail to cover the creation and validation of reliable assessment tools suitable for the Thai context. The absence of quality assessment tools hinders educators and administrators from accurately analyzing students' digital literacy status, impacting the planning of effective teaching strategies tailored to students' needs. As a result, this research sought to create a dependable and valid digital literacy assessment for Thai students in grades 10-12. The study aimed to achieve two goals: 1) to create and validate a digital literacy assessment tool's quality for students in Grades 10-12 within the Thai educational framework, and 2) to develop T-score norms derived from the results of the digital literacy assessment tool for students in Grades 10-12 in this context.

2. Methodology

2.1 Research Design

The research and development (R&D) approach was used as the core principle in the process to develop and validate an assessment tool for measuring digital literacy among Grade 10-12 students in the Thai context. The process involved three key steps. The assessment tool was developed based on a systematic review of digital literacy frameworks which was followed by expert evaluations for content validity using the Item-Objective Congruence (IOC) index. The tool's construct validity was tested through a confirmatory factor analysis (CFA) using pilot data from a sample of Grade 10-12 students. Items not meeting validity thresholds were revised or removed. Finally, the tool was administered to a larger student sample to establish T-score norms, enabling standardized interpretation of individual performance relative to the sample.

2.2 Participants

The population for this study were 28,177 Grade 10-12 students from 39 schools under the Phetchabun Secondary Educational Service Area Office which as a public organization taking control of schools under the ministry of education in the area during the 2024 academic year. A sample of 1,590 students was selected using stratified random sampling, ensuring representation across school sizes—small, medium, large, and extra-large—based on the criteria set by Thailand's Office of the Basic Education Commission. Schools were

first categorized by size, and 50% from each category were randomly selected, resulting in 21 schools. From these schools, a specific number of students were chosen through simple random sampling.

There were two groups of samples. Group 1 consisted of 136 students from two schools, and was used for initial assessment tool validation, including checks for item clarity, discrimination, and reliability. Group 2, comprising 1,454 students (478 Grade 10, 491 Grade 11, and 485 Grade 12 students), was used to test the construct validity through confirmatory factor analysis (CFA) and establish T-score norms.

2.3 Instruments

The research employed a digital literacy assessment tool for Grade 10-12 students as a sole instrument of the study. The assessment was divided into two sections. Particularly, the first section was to collect demographic information of the participants. It included the aspects of gender, grade level, and school. The second section involved 54 situational four multiple-choice questions designed to assess six components of digital literacy. In detail, there were 9 items in the aspects of digital technology usage skills, 9 items in digital media literacy, 9 items in critical thinking and problem-solving, 9 items in communication and creativity, 9 items in digital safety, and 9 items in ethics and appropriate behavior in the digital society.

2.4 Data Collection and Data Analysis

The development and validation of the digital literacy assessment tool for Grade 10-12 students involve the following processes. Initially, a literature review was conducted to define the components and behavioral indicators of digital literacy and to establish the research framework. Experts evaluated the tool's content validity using the Index of Congruence (IOC). 72 initially created items derived from the process. The predetermining criteria were set to ensure the scores ranging from 0.60 to 1.00. The tool was then piloted with 136 students to evaluate its difficulty, discrimination, and reliability. Subsequently, 54 questions across six components including digital technology usage, media literacy, critical thinking and problem-solving, communication and creativity, digital safety, and ethics in the digital society were finalized based on expert feedback and pilot results. The finalized tool was tested with a larger sample of 1,454 students, and its construct validity was confirmed through confirmatory factor analysis (CFA), which showed excellent fit indices (e.g., CFI = 1.00, RMSEA = 0.00). The reliability scores (KR-20) for the overall tool and individual components ranged from 0.70 to 0.94. T-score norms were then developed for interpreting student performance, ensuring the tool's reliability and applicability for assessing digital literacy in Thai high school students of grades 10-12.

3. Results

3.1 Content Validity and Items Analysis of the Assessment Tool

The digital literacy assessment tool was developed and refined through expert validation and item analysis. The results indicate that in terms of content validity, the components, behavioral indicators, and definitions were evaluated by experts, resulting in Index of Congruence (IOC) values of 0.6-1.0. Subsequently, items were revised based on expert feedback to ensure alignment with the intended objectives and comprehensive coverage of digital literacy components.

For item analysis, the tool was piloted with 136 students. The analysis of items shows an appropriate level of difficulty ($p = 0.6$ to 0.81), and discrimination ($r = 0.29$ - 0.79). Out of the initially created 72 items, 54 met the quality criteria, representing 75% of the total items. The overall reliability of the tool (KR-20) was 0.89, with component reliability scores as follows: digital technology usage (0.71), media literacy (0.59), critical thinking and problem-solving (0.66), communication and creativity (0.84), digital safety (0.65), and ethics in the digital society (0.75). The finalized tool comprises 54 multiple-choice situational questions, with a binary scoring system (0 for incorrect, 1 for correct).

The refined tool was further validated with a larger sample of 1,454 students, confirming its construct validity and high reliability (KR-20 = 0.94), with component reliability scores ranging from 0.70 to 0.83. The results indicate that the assessment tool effectively measures the intended digital literacy competencies.

3.2 Construct Validity of the Assessment Tool

The processes of confirmatory factor analysis indicate the following results.

The first-order CFA validated the six components of the digital literacy assessment tool, each comprising three behavioral indicators. In detail, for digital technology usage skills, behavioral indicators correlated significantly ($p < 0.01$), with factor loadings ranging from 0.61 to 0.69 and explaining 37-49% of the variance. The highest-weighted behavior was "using software and applications. In terms of digital media literacy, significant correlations ($p < 0.01$) were observed, with factor loadings of 0.76-0.77, explaining 59-60% of the variance.

"Using tools to verify facts" was the most significant indicator. In critical thinking and problem-solving, indicators correlated significantly ($p < 0.01$), with loadings from 0.35 to 0.90, explaining 12-82% of the variance. The highest-weighted behavior was "analyzing and evaluating digital information." In terms of communication and creativity, significant correlations ($p < 0.01$) were found, with factor loadings between 0.58 and 0.81, explaining 34-66% of the variance. "Collaborating in digital platforms" was the top behavior. In digital safety, significant correlations ($p < 0.01$), with factor loadings of 0.55-0.74, explained 30-55% of the variance. The leading behavior was "Knowledge of personal data protection." Lastly, for ethics and appropriate behavior, correlations were significant ($p < 0.01$), with loadings ranging from 0.74 to 0.87, explaining 55-76% of the variance. The most critical behavior was "avoiding inappropriate use of digital technology."

Moreover, The second-order cfa confirmed the overall model structure, comprising six components and 18 behavioral indicators. positive correlations ($p < 0.01$) were observed, with coefficients ranging from 0.20 to 0.71. fit indices ($\chi^2 = 74.52$, $df = 79$, $\chi^2/df = 0.94$, $p\text{-value} = 0.621$, $CFI = 1.00$, $TLI = 1.00$, $RMSEA = 0.00$ and $SRMR = 0.01$) demonstrated excellent alignment with empirical data, validating the structural integrity of the digital literacy assessment model. The details of the confirmatory factor analysis can be seen in table 1.

Table 1. Confirmatory factor analysis

Behavioral indicator	Factor loading		S.E.	Z	p-value	R-squared	Factor Score Coefficient
	b	β					
First-order confirmatory factor analysis							
1. Component: Digital Technology Usage Skills (DT)							
1.1 Ability to operate digital devices	1.00	0.70	0.02	37.44	0.00	0.49	0.16
1.2 Using software and applications	1.14	0.64	0.02	34.50	0.00	0.41	0.11
1.3 Connecting to and using internet networks	1.17	0.64	0.02	30.16	0.00	0.40	0.13
2. Component: Digital Media Literacy (DM)							
2.1 Ability to evaluate the credibility of digital information sources	1.00	0.76	0.01	56.68	0.00	0.58	0.13
2.2 Identifying and distinguishing fake news from real news	1.11	0.78	0.01	62.38	0.00	0.60	0.11
2.3 Using tools to verify facts	1.14	0.77	0.01	60.98	0.00	0.60	0.12
3. Component: Critical Thinking and Problem-Solving (CP)							
3.1 Analyzing and evaluating information from digital sources	1.00	0.71	0.02	40.47	0.00	0.51	0.11
3.2 Using reasoning and evidence to assess information	0.82	0.67	0.02	36.45	0.00	0.44	0.08
3.3 Solving problems using digital technology	0.44	0.34	0.03	13.57	0.00	0.12	0.01
4. Component: Communication and Creativity (CC)							
4.1 Creating and sharing digital content	1.00	0.59	0.02	30.73	0.00	0.35	0.04
4.2 Communicating via social media platforms	1.43	0.75	0.01	58.31	0.00	0.56	0.06
4.3 Collaborating on digital platforms and engaging in digital communities	1.83	0.88	0.01	96.82	0.00	0.78	0.15
5. Component: Digital Safety (DS)							
5.1 Knowledge of methods for securing personal data	1.00	0.80	0.02	48.36	0.00	0.64	0.21
5.2 Setting privacy configurations on digital platforms	0.53	0.52	0.02	24.68	0.00	0.27	0.07
5.3 Preventing online threats	0.81	0.66	0.02	32.72	0.00	0.43	0.12
6. Component: Ethics and Appropriate Behavior in the Digital Society (EA)							
6.1 Respecting copyrights and intellectual property rights of others	1.00	0.75	0.01	57.51	0.00	0.56	0.11
6.2 Adhering to ethical principles in	1.14	0.82	0.01	78.76	0.00	0.67	0.17

Behavioral indicator	Factor loading		S.E.	Z	p-value	R-squared	Factor Score Coefficient
	b	β					
digital technology use							
6.3 Avoiding inappropriate use of digital technology	1.25	0.86	0.01	95.92	0.00	0.74	0.21
Second-order confirmatory factor analysis							
1. Digital Technology Usage Skills	1.00	0.90	0.02	56.29	0.00	0.81	-
2. Digital Media Literacy	1.37	0.95	0.01	124.40	0.00	0.92	-
3. Critical Thinking and Problem-Solving	1.47	0.96	0.02	63.40	0.00	0.93	-
4. Communication and Creativity	1.08	0.98	0.01	120.72	0.00	0.98	-
5. Digital Safety	1.58	0.94	0.02	59.74	0.00	0.90	-
6. Ethics and Appropriate Behavior in the Digital Society	1.46	0.93	0.01	122.56	0.00	0.87	-
$\chi^2 = 74.52, df = 79, \chi^2/df = 0.94, p\text{-value} = 0.621, CFI = 1.00, TLI = 1.00, RMSEA = 0.00, SRMR = 0.01$							

It could be seen that the second-order confirmatory factor analysis validated the digital literacy model, comprising six components with 18 behavioral indicators. All indicators had positive factor loadings ranging from 0.34 to 0.88, with significant contributions to digital literacy. The highest-weighted indicators were "collaborating on digital platforms and engaging in digital communities," "avoiding inappropriate use of digital technology," and "adhering to ethical principles in digital technology use."

Among the six components:

1. Communication and Creativity contributed the most, with loadings of 0.59-0.88, explaining 35-78% of the variance.
2. Critical Thinking and Problem-Solving followed, with loadings of 0.34-0.71, explaining 12-51% of the variance.
3. Digital Media Literacy had strong loadings (0.76-0.78) and explained 58-60% of the variance.
4. Digital Safety explained 27-64% of the variance with loadings of 0.52-0.80.
5. Ethics and Appropriate Behavior explained 56-74% of the variance with loadings of 0.75-0.86.
6. Digital Technology Usage Skills had the lowest contribution, with loadings of 0.64-0.70, explaining 40-49% of the variance.

The overall model fit indices ($\chi^2 = 74.52, df = 79, \chi^2/df = 0.94, p\text{-value} = 0.621, CFI = 1.00, TLI = 1.00, RMSEA = 0.00$ and $SRMR = 0.01$) indicated excellent alignment with empirical data. The six components collectively explained 81-98% of the variance in digital literacy, confirming the model's validity and the importance of these components in assessing digital literacy among high school students. This can be modeled into figure 1.

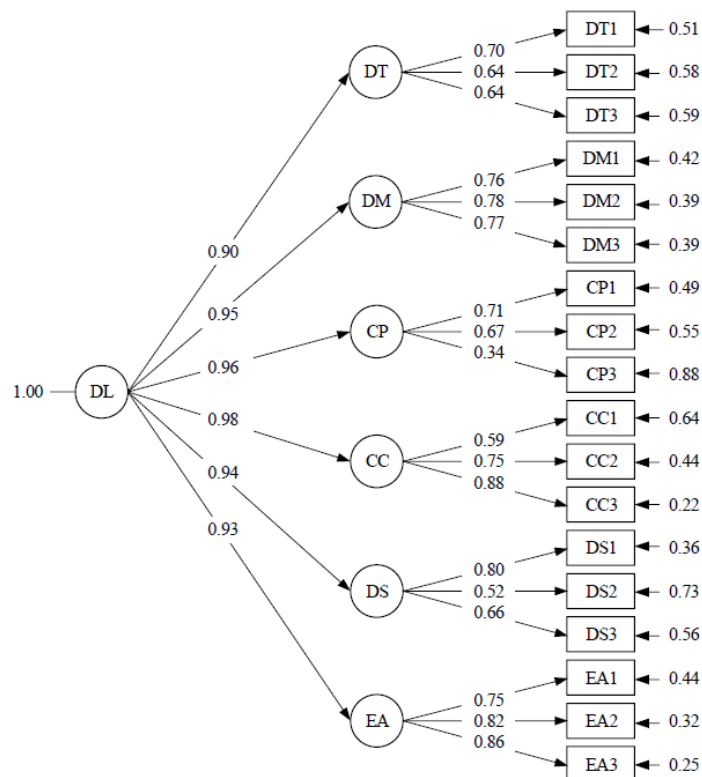

Figure 1. Results of Confirmatory Factor Analysis for the Digital Literacy Model

3.3 T-Score Norm Development for the Digital Literacy Assessment Scores

Table 2. Students' Digital Literacy Score

Students' Digital Literacy Score (54 Marks)					
Score	Percentile	t-score	Score	Percentile	t-score
53	99.97	85	29	26.89	44
52	97.76	70	28	25.83	44
51	94.64	66	27	25.17	43
50	92.78	65	26	24.24	43
49	90.96	63	25	23.56	43
48	88.82	62	24	23.25	43
47	85.59	61	23	22.39	42
46	81.64	59	22	21.22	42
45	77.17	57	21	20.12	42
44	71.70	56	20	18.81	41
43	65.44	54	19	17.40	41
42	59.28	52	18	15.51	40
41	53.75	51	17	13.24	39
40	48.25	50	16	10.87	38
39	43.78	48	15	8.56	36
38	40.82	48	14	6.12	35
37	38.55	47	13	3.68	32
36	36.45	47	12	2.06	30
35	34.39	46	11	1.00	27
34	32.53	45	10	0.45	24
33	31.19	45	9	0.28	22
32	30.12	45	7	0.10	19
31	29.16	45	6	0.03	16
30	28.27	44			

The percentile ranks and normalized T-scores were calculated to create a scoring interpretation table for each component and overall digital literacy. The following identifies the level of digital literacy among Grade 10-12 students in the Thai educational context.

Digital Technology Usage Skills: Raw scores ranged from 0-9, with T-scores from T20-T65.

Digital Media Literacy: Raw scores ranged from 0-9, with T-scores from T24-T62.

Critical Thinking and Problem-Solving: Raw scores ranged from 0-9, with T-scores from T25-T74.

Communication and Creativity: Raw scores ranged from 0-9, with T-scores from T27-T66.

Digital Safety: Raw scores ranged from 0-9, with T-scores from T26-T77.

Ethics and Appropriate Behavior in the Digital Society: Raw scores ranged from 0-9, with T-scores from T27-T60.

In conclusion, raw scores ranged from 6-53, with T-scores from T16-T85. A student scoring 40 raw points corresponds to a T-score of T50, representing the median digital literacy level of the student population.

4. Discussion

The CFA results demonstrated that the digital literacy model fit the data exceptionally well. Fit indices such as $\chi^2 = 74.52$, $df = 79$, $\chi^2/df = 0.94$, $p\text{-value} = 0.621$, $CFI = 1.00$, $TLI = 1.00$, $RMSEA = 0.00$ and $SRMR = 0.01$ indicate a strong alignment between the six-component structure and the empirical data. These results validate the theoretical framework underlying the digital literacy model and confirm its suitability for assessing digital literacy in Grade 10-12 students. The excellent fit indices suggest that the tool captures the intended constructs effectively and can be reliably used in educational settings.

All factor loadings were positive and statistically significant, ranging from 0.34 to 0.88 across the six components. These results provide strong support for the construct validity of the assessment tool, confirming that the selected indicators are robust measures of the components. For example, within the "Communication and Creativity" component, the highest loading (0.88) was observed for "collaborating on digital platforms and engaging in digital communities," highlighting the critical role of collaborative skills in digital literacy.

The six components collectively explained between 12% and 78% of the variance in digital literacy, with varying contributions from each component. "Communication and Creativity" accounted for the highest variance (35-78%), underscoring its importance in digital literacy development. Conversely, "Digital Technology Usage Skills" explained a smaller portion of the variance (40-49%), suggesting that these foundational skills may already be well-established among students and less differentiated within the population.

The findings align with prior research, particularly the emphasis on collaborative and creative skills as central to digital literacy. For instance, Buckingham (2015) highlighted the increasing importance of communication and content creation in digital environments, consistent with the high factor loadings observed in this study for "Communication and Creativity." Similarly, Eshet (2012) identified critical thinking and digital safety as essential dimensions of digital literacy, which were also validated as significant components in this study. However, the relatively lower contribution of "Digital Technology Usage Skills" contrasts with earlier research (e.g., Amin et al., 2021; Avinç & Doğan, 2024; Choi et al., 2023; Hermansen et al., 2023) which emphasized these foundational skills in the context of developing digital literacy. This divergence may reflect the evolving baseline proficiency in technology usage among high school students in the current digital age.

5. Conclusion

The study aimed to develop and validate a digital literacy assessment tool for Grade 10-12 students, focusing on six key components: Digital Technology Usage Skills, Digital Media Literacy, Critical Thinking and Problem-Solving, Communication and Creativity, Digital Safety, and Ethics and Appropriate Behavior in the Digital Society. The tool was designed as a situational multiple-choice test comprising 54 items and demonstrated robust validity and reliability across all components.

The study resulted in the creation of a systematically validated tool tailored to the Thai educational context. It effectively measures students' digital literacy levels, providing insights into specific strengths and weaknesses across the six components. The tool also includes T-score norms, enabling educators and policymakers to interpret students' performance relative to the larger population of Grade 10-12 students.

This tool contributes significantly to the field as a comprehensive and culturally relevant measure of digital literacy, addressing the need for valid and reliable assessment methods in the Thai education system. Its systematic design ensures it can serve as a benchmark for evaluating and improving digital literacy at both institutional and regional levels.

The assessment tool provides educators with actionable insights to tailor instruction and interventions aimed at enhancing specific digital literacy components. For example, teachers can focus on improving critical thinking and ethical behavior in digital contexts based on the tool's results. This study paves the way for further exploration into digital literacy across different student populations and educational levels. Future research could adapt and validate the tool for younger students or other regions, enabling broader comparisons and applicability.

While the study successfully developed and validated the tool, its application was limited to a specific region and student population. Expanding the sample to include diverse geographical and educational settings would strengthen the generalizability of the findings. Additionally, future studies should explore longitudinal applications of the tool to track digital literacy development over time.

Competing interests

The authors declare that they have no known competing financial interests or personal relationships that could have appeared to influence the work reported in this paper.

Informed consent

Obtained.

Ethics approval

The Publication Ethics Committee of the Canadian Center of Science and Education.

The journal's policies adhere to the Core Practices established by the Committee on Publication Ethics (COPE).

Provenance and peer review

Not commissioned; externally double-blind peer reviewed.

Data availability statement

The data that support the findings of this study are available on request from the corresponding author. The data are not publicly available due to privacy or ethical restrictions.

Data sharing statement

No additional data are available.

Open access

This is an open-access article distributed under the terms and conditions of the Creative Commons Attribution license (<http://creativecommons.org/licenses/by/4.0/>).

Copyrights

Copyright for this article is retained by the author(s), with first publication rights granted to the journal.

References

- Amin, H., Malik, M. A., & Akkaya, B. (2021). Development and Validation of Digital Literacy Scale (DLS) and its Implication for Higher Education. *International Journal of Distance Education and E-Learning*, 7(1), Article 1. <https://doi.org/10.36261/ijdeel.v7i1.2224>
- Arik, K., & Kıyıcı, M. (2019). Identifying Digital Literacy of High School Students: A Case of Hendek. *Sakarya University Journal of Education*, 9(1), Article 1. <https://doi.org/10.19126/suje.448789>
- Avinç, E., & Doğan, F. (2024). Digital literacy scale: Validity and reliability study with the rasch model. *Education and Information Technologies*. <https://doi.org/10.1007/s10639-024-12662-7>
- Buckingham, D. (2015). Defining Digital Literacy. In B. Bachmair (Ed.), *Medienbildung in neuen Kulturräumen: Die deutschsprachige und britische Diskussion* (pp. 59-71). VS Verlag für Sozialwissenschaften. https://doi.org/10.1007/978-3-531-92133-4_4
- Castek, J., Manderino, M., & Jacobs, G. E. (2018). Digital Problem Solving: The Literacies of Navigating Life in the Digital Age. *Journal of Adolescent & Adult Literacy*, 61(6), 681-685. <https://doi.org/10.1002/jaal.745>
- Choi, J., Choi, S., Song, K., Baek, J., Kim, H., Choi, M., Kim, Y., Chu, S. H., & Shin, J. (2023). Everyday Digital Literacy Questionnaire for Older Adults: Instrument Development and Validation Study. *Journal of Medical Internet Research*, 25(1), e51616. <https://doi.org/10.2196/51616>
- Eshet, Y. (2012). Thinking in the Digital Era: A Revised Model for Digital Literacy. *Issues in Informing Science and Information Technology*, 9, 267-276. <https://doi.org/10.28945/1621>

- Hennessy, S., D'Angelo, S., McIntyre, N., Koomar, S., Kreimeia, A., Cao, L., Brugha, M., & Zubairi, A. (2022). Technology Use for Teacher Professional Development in Low- and Middle-Income Countries: A systematic review. *Computers and Education Open*, 3, 100080. <https://doi.org/10.1016/j.caeo.2022.100080>
- Hermansen, Å., Andersen, M. H., Borge, C. R., Dahl, K. G., Larsen, M. H., Lønning, K., Meyer, K. B., Vidnes, T. K., & Wahl, A. K. (2023). Preliminary validity testing of the eHealth Literacy Questionnaire (eHLQ): A Confirmatory Factor Analysis (CFA) in Norwegian hospitalized patients. *BMC Psychology*, 11(1), 409. <https://doi.org/10.1186/s40359-023-01449-z>
- Janthapassa, S., Chanthapassa, N., & Kenaphoom, S. (2024). The role of digital literacy in shaping education in the next-normal. *Asian Education and Learning Review*, 2(1), Article 1. <https://doi.org/10.14456/aclr.2024.3>
- Laudato, E. E., & Punzalan, C. H. (2021). Digital Literacy of Selected Senior High School Students: An Analysis for Online Education Readiness. *Journal of Educational Technology*, 18(2), 53-62. <https://doi.org/10.26634/jet.18.2.17817>
- Livingstone, S., Ólafsson, K., Helsper, E. J., Lupiáñez-Villanueva, F., Veltri, G. A., & Folkvord, F. (2017). Maximizing Opportunities and Minimizing Risks for Children Online: The Role of Digital Skills in Emerging Strategies of Parental Mediation. *Journal of Communication*, 67(1), 82-105. <https://doi.org/10.1111/jcom.12277>
- Sayavaranont, P., & Wannapiroon, P. (2017). Why Generation Z' Digital Literacy can be Improved through Digital Storytelling? Purita Sayavaranont and Panita Wannapiroon. *Journal of Mass Communication Technology, RMUTP*, 2(1), Article 1.
- The Ministry of Education. (2008). *The basic education core curriculum*. The Ministry of Education.
- Yeşilyurt, E., & Vezne, R. (2023). Digital literacy, technological literacy, and internet literacy as predictors of attitude toward applying computer-supported education. *Education and Information Technologies*, 28(8), 9885-9911. <https://doi.org/10.1007/s10639-022-11311-1>
- Yuangsoi, P., & Wannakhao, C. (2023). Digital literacy skills for learning in the new normal. *Journal of Graduate School Sakon Nakhon Rajabhat University*, 20(91), Article 91.